

Simple  friendly



**Kawasaki Robot  
BA Series**

**Installation and  
Connection Manual**

**Robot**

**Kawasaki Heavy Industries, Ltd.**

## PREFACE

This manual describes installation and connection procedures for Kawasaki Robot BA Series.

Read and understand the contents of this and safety manuals thoroughly and strictly observe all rules for safety before proceeding with any operation. Kawasaki cannot take any responsibility for any accidents and/or damages caused by operations that are based on only the limited part of this manual.

This manual describes only the installation and connection of the Robot Arm. Please refer to the following manual for installation and connection of Controller and for Arc-welding Robots.

“Installation and Connection Manual” for controller

“Installation and Connection Manual” for arc welding

This manual is applicable to the following robot arms.

BA006L, BA006N

- 
1. This manual does not constitute a guarantee of the systems in which the robot is utilized. Accordingly, Kawasaki is not responsible for any accidents, damages, and/or problems relating to industrial property rights as a result of using the system.
  2. It is recommended that all personnel assigned for activation of operation, teaching, maintenance or inspection of the robot attend the necessary education/training course(s) prepared by Kawasaki, before assuming their responsibilities.
  3. Kawasaki reserves the right to change, revise, or update this manual without prior notice.
  4. This manual may not, in whole or in part, be reprinted or copied without the prior written consent of Kawasaki.
  5. Store this manual with care and keep it available for use at any time. If the robot is reinstalled or moved to a different site or sold off to a different user, attach this manual to the robot without fail. In the event the manual is lost or damaged severely, contact Kawasaki.

---

Copyright © 2016 Kawasaki Heavy Industries Ltd. All rights reserved.

## SYMBOLS

The items that require special attention in this manual are designated with the following symbols.

Ensure proper and safe operation of the robot and prevent physical injury or property damages by complying with the safety matters given in the boxes with these symbols.

 **DANGER**

**Failure to comply with indicated matters can result in imminent injury or death.**

 **WARNING**

**Failure to comply with indicated matters may possibly lead to injury or death.**

 **CAUTION**

**Failure to comply with indicated matters may lead to physical injury and/or mechanical damage.**

**[ NOTE ]**

Denotes precautions regarding robot specification, handling, teaching, operation, and maintenance.

 **WARNING**

- 1. The accuracy and effectiveness of the diagrams, procedures, and detail explanations given in this manual cannot be confirmed with absolute certainty. Accordingly, it is necessary to give one's fullest attention when using this manual to perform any work. Should any unexplained questions or problems arise, please contact Kawasaki.**
- 2. Safety related contents described in this manual apply to each individual work and not to all robot work. In order to perform every work in safety, read and fully understand the safety manual, all pertinent laws, regulations and related materials as well as all the safety explanations described in each chapter, and prepare safety measures suitable for actual work.**

## CONTENTS

1.0	Precautions .....	4
1.1	Precautions During Transportation, Installation and Storage .....	4
1.2	Installing Environment of Robot Arm .....	5
1.3	Warning Label .....	6
2.0	Work Flow at Arm Installation and Connection .....	7
3.0	Motion Range & Specifications of Robot.....	8
3.1	Determination of Safety Fence Installation Location.....	8
3.2	Motion Range & Specifications of Robot.....	9
4.0	Robot Transportation Method .....	11
4.1	Using Wire Sling (Without Base Plate) .....	11
4.2	Using Wire Sling (With Base Plate) .....	12
5.0	Installation Dimensions of Base Section .....	13
6.0	Dimensions of Robot Pedestal .....	14
7.0	Installation Method .....	15
7.1	When Installing the Robot Directly on the Floor .....	15
7.2	When Installing the Robot Pedestal on the Floor .....	16
7.3	When Installing the Robot Base Plate on the Floor.....	17
8.0	Mounting of Tools .....	18
8.1	Dimensions of Wrist End .....	18
8.2	Specification of Mounting Bolt.....	18
8.3	Load Capacity .....	19
9.0	Mounting External Equipment.....	21
9.1	Service Tapped Hole Positions .....	21

## 1.0 PRECAUTIONS

### 1.1 PRECAUTIONS DURING TRANSPORTATION, INSTALLATION AND STORAGE

When transporting the Kawasaki Robot to its installation site, strictly observe the following cautions.



#### WARNING

1. When the robot arm is to be transported by using a crane or forklift, never support the robot arm manually.
2. During transportation, never climb on the robot arm or stay under the hoisted robot arm.
3. Prior to installation, turn OFF the controller power switch and the external power switch for shutting down power supply to the controller. Display signs indicating clearly “Installation and connection in progress”, and lockout/tagout the external power switch to prevent accidents of electric shock etc. caused when someone accidentally turns ON the power.
4. Prior to moving robot, ensure safety by first confirming no abnormality is observed in installing condition, etc., and then turn ON motor power to set robot to the desired pose. Be careful not to be caught by/between any moving parts due to careless approach to robot and peripheral equipment. After setting robot to the specified pose, turn OFF the controller power and the external power switch again as mentioned above. Display signs indicating clearly “Installation and connection in progress”, and lockout/tagout the external power switch before starting installation and connection.



#### CAUTION

1. Since the robot arm is composed of precision parts, be careful not to apply excessive shocks or vibrations during transportation.
2. Prior to installation, remove all obstacles so the installation is carried out smoothly and safely. Clear a passage to the installation area for transportation of the robot arm using a crane or forklift.
3. During transportation and storage,
  - (1) Keep the ambient temperature within the range of -10 to 60 °C,
  - (2) Keep the relative humidity within the range of 35 – 85 % RH without dew condensation,
  - (3) Keep free from excessively strong vibration.

## 1.2 INSTALLING ENVIRONMENT OF ROBOT ARM

The robot arm must be installed in a place that satisfies all the following environmental conditions:

1. When robot is installed on the floor, the levelness must be within  $\pm 5^\circ$ .
2. Be sure that the installation floor/pedestal has sufficient rigidity.
3. Secure a flatness to prevent undue force applied to the installation section. (If sufficient flatness is unobtainable, insert liners and adjust the flatness.)
4. Keep the ambient temperature during operation within the range of 0 to 45 °C. (Deviation or overload error may occur due to high viscosity of grease/oil when starting operation at low temperatures. In this case, move the robot at low speed before regular operation.)
5. Keep the relative humidity during operation within the range of 35-85 %RH without dew condensation.
6. The robot installing place should be free from dust, dirt, oil, smoke, water, and other foreign matters.
7. The robot installing place should be free from flammable or corrosive liquid or gas.
8. The robot installing place should be free from excessively strong vibration. (0.5G or less)
9. The robot installing place should be free from electric noise interference.
10. The robot installing place should be sufficiently larger than the motion range of robot arm.
  - (1) Install safety fence so the maximum movement of fully equipped robot arm (with tools) does not cause interference.
  - (2) Minimize the number of entrance gates (only one is best) and equip the entrance gate with a safety plug.
  - (3) Observe the requirements of JIS B8433, etc. established in each region for details of the safety fence.

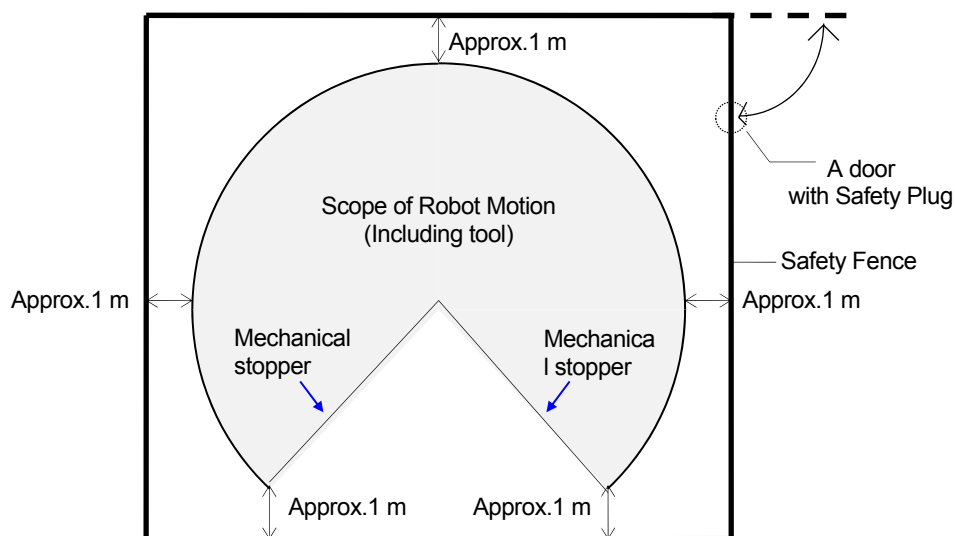

### 1.3 WARNING LABEL

 **WARNING**

Pay attention to the warning labels listed in the drawings below.



Warning label for high temperature



Warning label for pinching

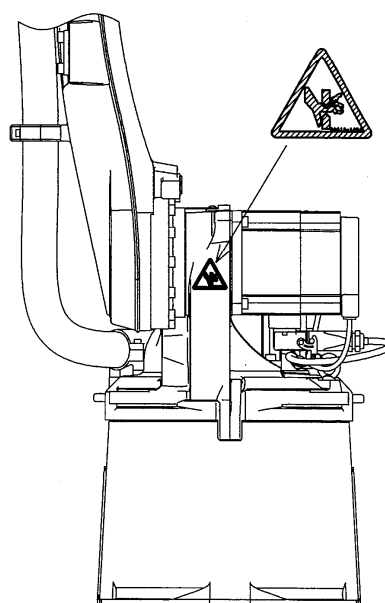
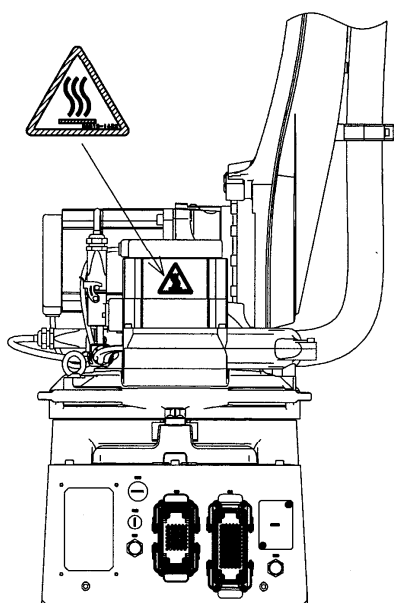
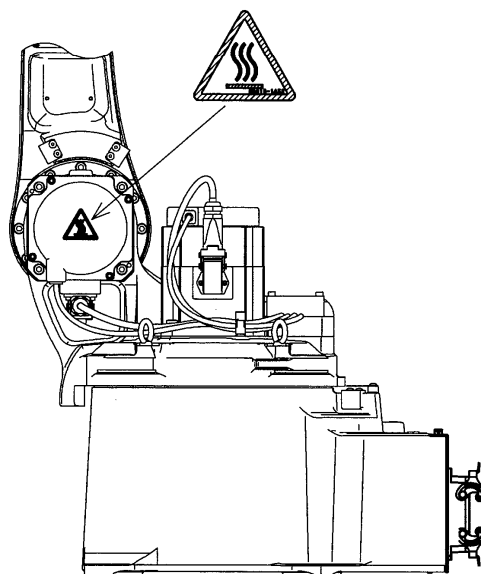

## 2.0 WORK FLOW AT ARM INSTALLATION AND CONNECTION

This workflow describes only the robot arm section. For the controller, refer to “Installation and Connection Manual” for controller.

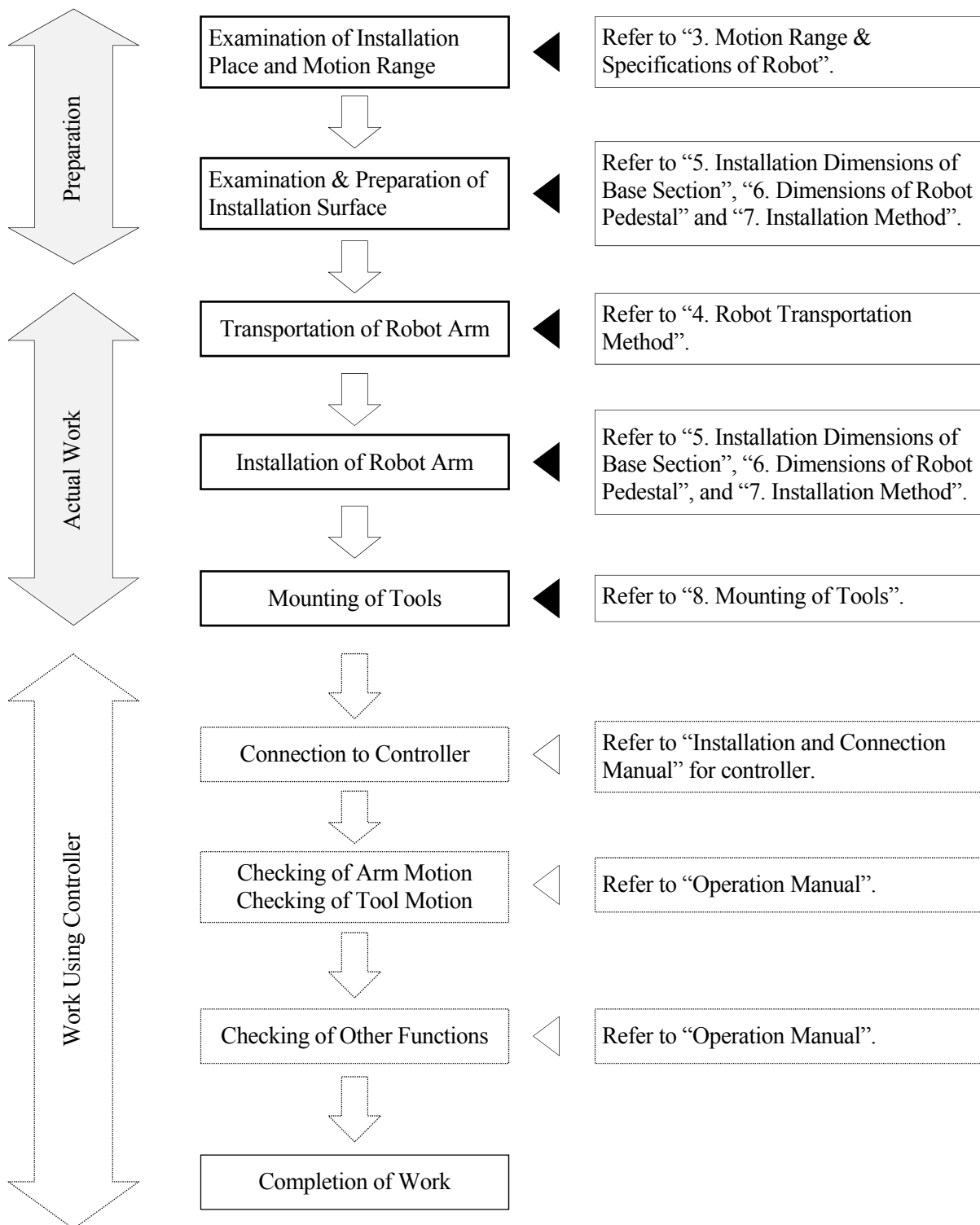



### 3.0 MOTION RANGE & SPECIFICATIONS OF ROBOT

#### 3.1 DETERMINATION OF SAFETY FENCE INSTALLATION LOCATION

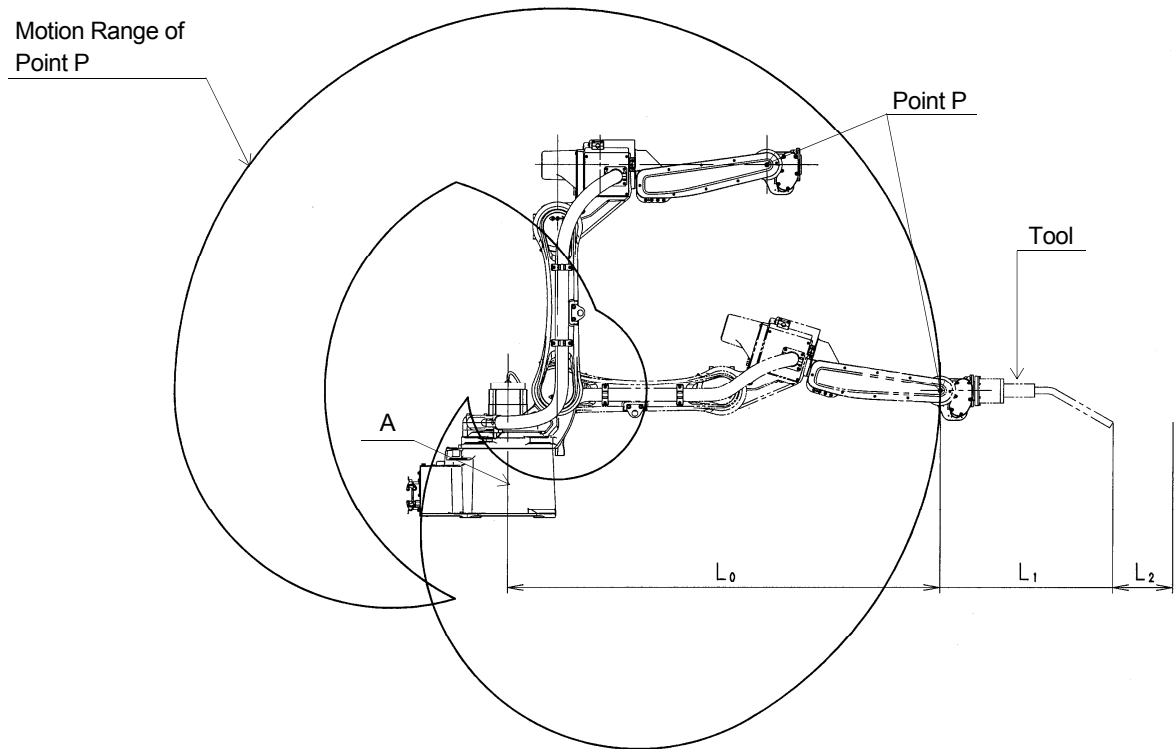

The motion range of the robot is represented by the maximum area that can be covered by point P in the figure above. Therefore, as shown in the figure below, install the safety fence outside circle whose radius is  $L_0+L_1+L_2$ . Where;  $L_0$  is the length from the center line of arm (point A shown above) to the farthest point of P,  $L_1$  is the length from point P to the farthest point of tool, and  $L_2$  is safety margin. For the length of  $L_0$ , refer to the drawings in the section 3.2.

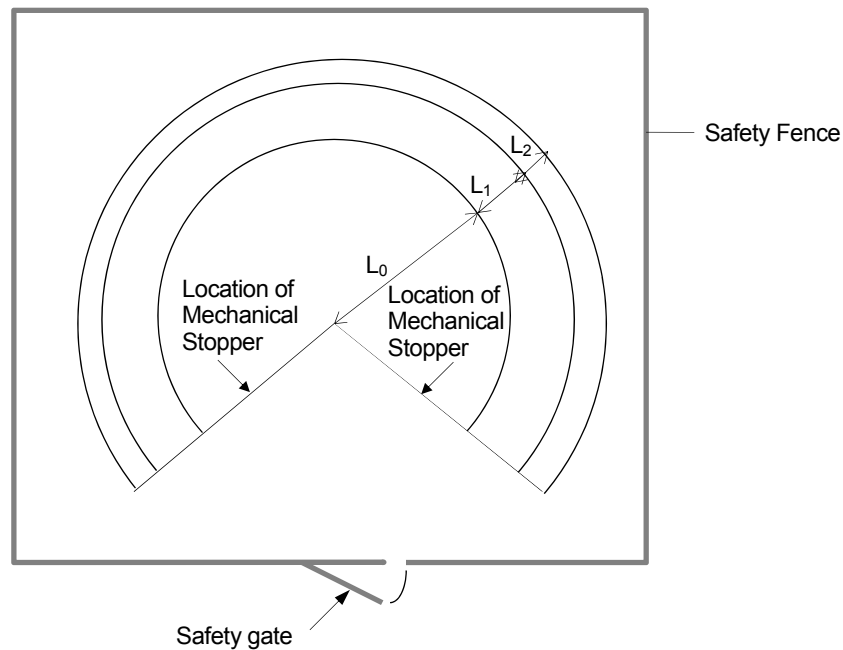

**3.2 MOTION RANGE & SPECIFICATIONS OF ROBOT  
BA006L**

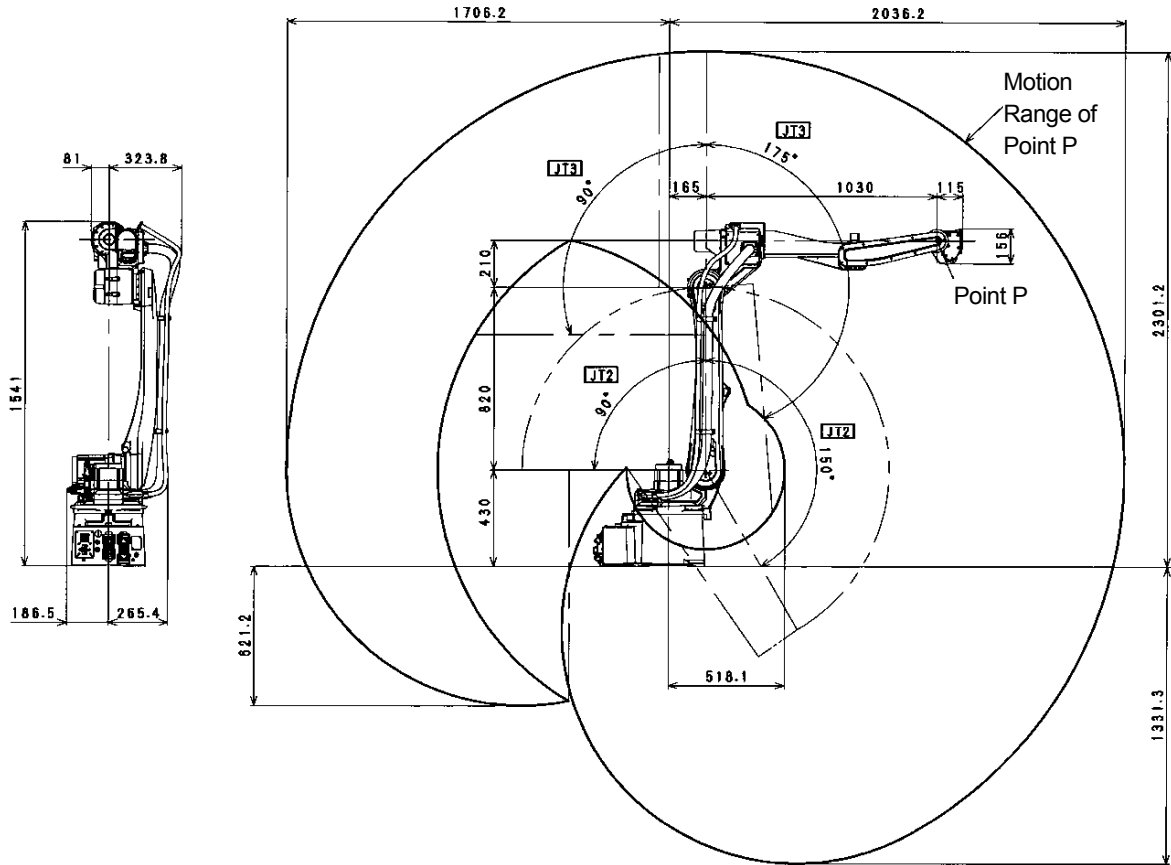

Type	Articulated Robot		
Degree of Freedom	6		
Motion Range and Maximum Speed	JT	Motion Range	Max. Speed
	1	±165°	210 °/s
	2	+150° to -90°	210 °/s
	3	+90° to -175°	220 °/s
	4	±180°	430 °/s
	5	±135°	430 °/s
6	±360°	650 °/s	
Max. Payload	6 kg		
Wrist Load Capacity	JT	Torque	Moment of Inertia
	4	12 N·m	0.4 kg·m <sup>2</sup>
	5	12 N·m	0.4 kg·m <sup>2</sup>
6	3.75 N·m	0.07 kg·m <sup>2</sup>	
Repeatability	±0.08 mm		
Mass	160 kg		
Acoustic noise	< 70 dB (A)*		

\*measured condition  
 • installed on the plate rigidly fixed on the floor  
 • 3600 mm away from JT1 center

The noise level depends on the conditions.

**BA006N**

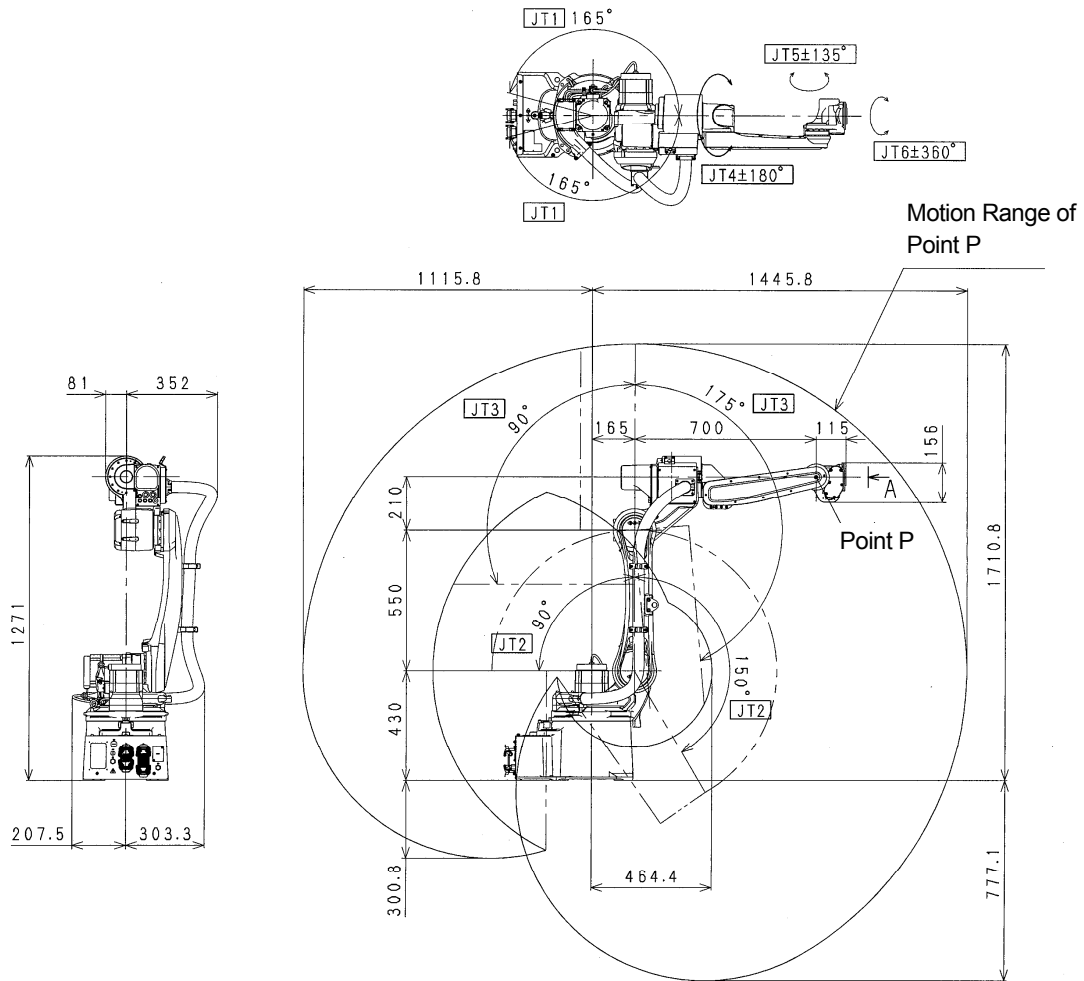

Type	Articulated Robot		
Degree of Freedom	6		
Motion Range and Maximum Speed	JT	Motion Range	Max. Speed
	1	±165°	240 °/s
	2	+150° to -90°	240 °/s
	3	+90° to -175°	220 °/s
	4	±180°	430 °/s
	5	±135°	430 °/s
6	±360°	650 °/s	
Max. Payload	6 kg		
Wrist Load Capacity	JT	Torque	Moment of Inertia
	4	12 N·m	0.4 kg·m <sup>2</sup>
	5	12 N·m	0.4 kg·m <sup>2</sup>
6	3.75 N·m	0.07 kg·m <sup>2</sup>	
Repeatability	±0.06 mm		
Mass	150 kg		
Acoustic noise	< 70 dB (A)*		

\*measured condition  
 • installed on the plate rigidly fixed on the floor  
 • 3000 mm away from JT1 center

The noise level depends on the conditions.

## 4.0 ROBOT TRANSPORTATION METHOD

### 4.1 USING WIRE SLING (WITHOUT BASE PLATE)

As shown in the figure below, fasten wire slings to two eyebolts and a hoisting hole on the arm and hoist up the robot. (Use the same method for hoisting up the robot with pedestal.)

**! CAUTION**

**When hoisting up the robot, be careful as robot may lean forward/backward depending on robot posture and installation condition of the options. If the robot is hoisted up in an inclined posture, it may swing, damage or the wire may interfere with the harness, piping etc., or it may damage due to interfering with surrounding objects. Protect the robot with guard plates, etc. if wires interfere with a part of the robot.**

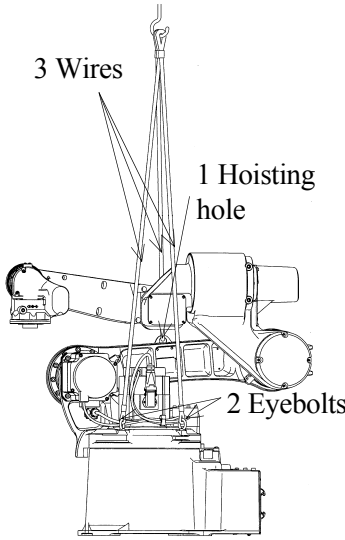
Model	All models	
Hoisted up posture		
Hoisted up posture	JT1	0°
	JT2	-85°
	JT3	-175°
	JT4	0°
	JT5	-90°
	JT6	0°
Hoisting parts on arm	Eyebolt M8 × 2	

## 4.2 USING WIRE SLING (WITH BASE PLATE)

According to the figure below, hoist up the robot by fastening four wire slings to four eyebolts on the base plate. In addition, fasten wire slings to a hoisting hole on the arm to prevent the robot from accidentally falling. (Use the same method for hoisting up the robot with pedestal.)

**! CAUTION**

**When hoisting up the robot, be careful as robot may lean forward/backward depending on robot posture and installation condition of the options. If the robot is hoisted up in an inclined posture, it may swing, damage or the wire may interfere with the harness, piping etc., or it may damage due to interfering with surrounding objects. Protect the robot with guard plates, etc. if wires interfere with a part of the robot.**

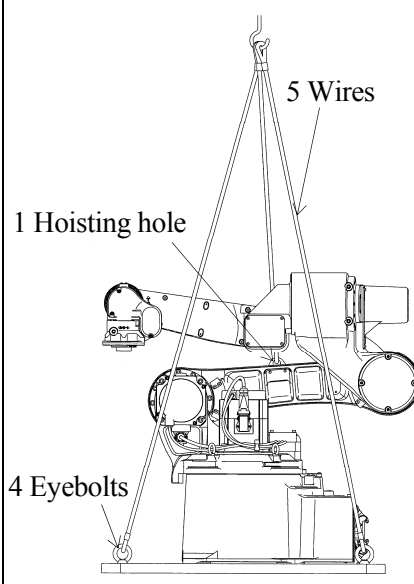
Model		All models
Hoisted up posture		
Hoisted up posture	JT1	0°
	JT2	-85°
	JT3	-175°
	JT4	0°
	JT5	-90°
	JT6	0°

### 5.0 INSTALLATION DIMENSIONS OF BASE SECTION

When installing a robot, fix the base section with high tension bolts through the bolt holes.

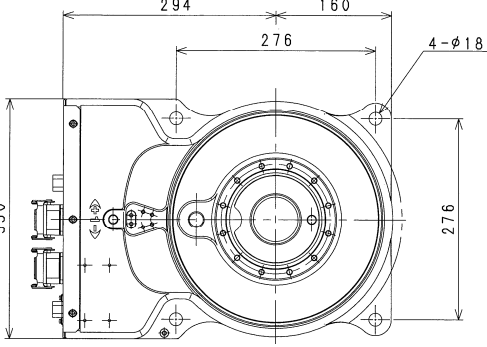
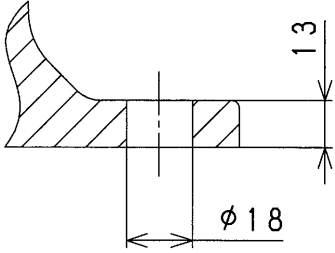
Model	All models
Dimensions for installation	 <p>The diagram shows a top view of the base section. It features a central circular hub with four mounting holes. The overall width is 294 units, and the distance between the centers of the two outer mounting holes is 160 units. The distance between the centers of the two inner mounting holes is 276 units. The overall height is 330 units, and the distance between the centers of the two bottom mounting holes is 276 units. There are four holes, each with a diameter of 18 units, labeled as 4-φ18.</p>
Cross-section of installation section	 <p>The diagram shows a cross-section of the installation section. It depicts a cylindrical hole with a diameter of 18 units, labeled as φ18. The height of the section is 13 units.</p>
Bolt hole	4-φ18
High tension bolt	4-M16 Material: SCM435 Strength class: 10.9 min.
Tightening torque	235 N·m
Levelness	Within ±5°

### 6.0 DIMENSIONS OF ROBOT PEDESTAL

When installing a robot on the pedestal, fix the pedestal with high tension bolts through the bolt holes.

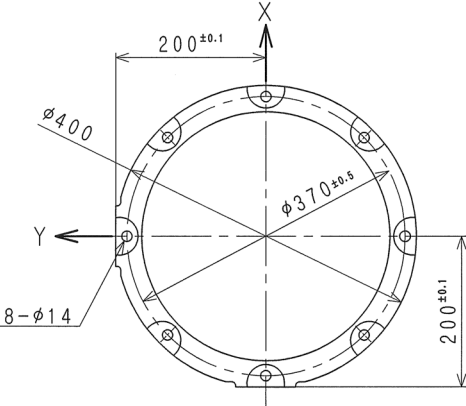
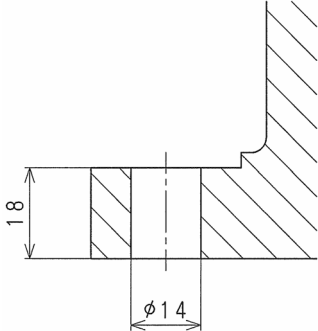
Model	All models
Dimensions for installation	
Cross-section of installation section	
Bolt hole	8-φ14
High tension bolt	8-M12 Material: SCM435 Strength class: 10.9 min
Tightening torque	98 N·m
Levelness	Within ±5°

## 7.0 INSTALLATION METHOD

### 7.1 WHEN INSTALLING THE ROBOT DIRECTLY ON THE FLOOR

In this case, bury steel plate of L2 thickness (See the table below.) in the concrete floor as shown in the figure below or fix it with anchors. Fix the steel plate firmly enough to endure the reaction forces produced by the robot.

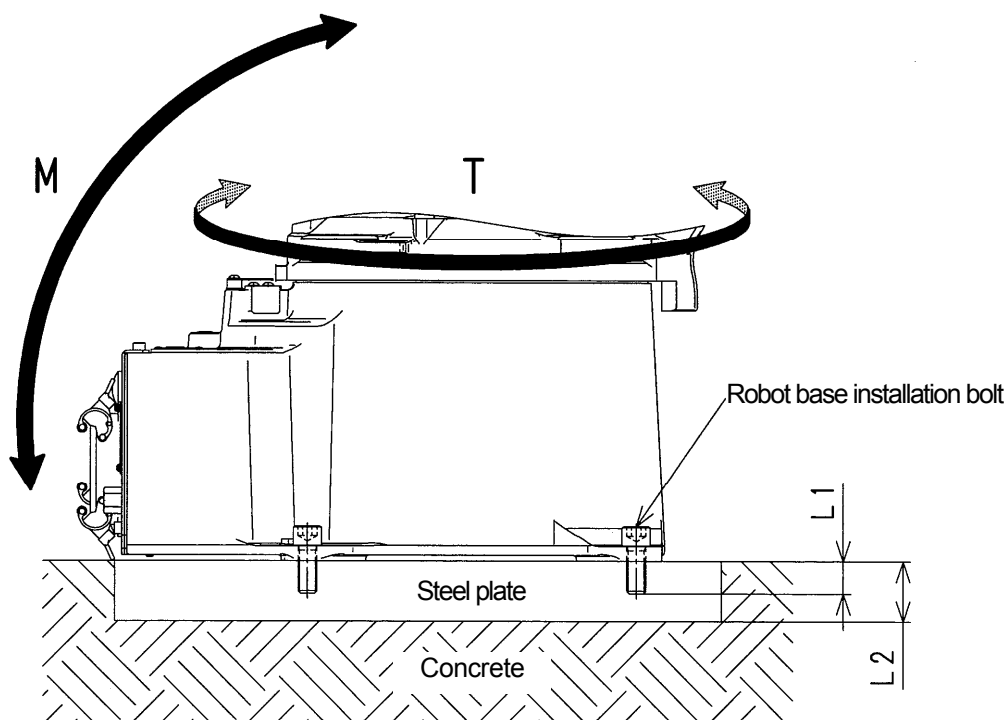

Model	BA006L	BA006N
M (Inversion moment)	2982 N·m	2527 N·m
T (Rotating torque)	2200 N·m	1935 N·m
Robot base installation bolt	4-M16	
Tightening torque	235 N·m	
L1	Min. 25 mm	
L2	Min. 28 mm	



## 7.2 WHEN INSTALLING THE ROBOT PEDESTAL ON THE FLOOR

In this case, the installation procedures are practically the same as the procedure shown in the section 7.1.

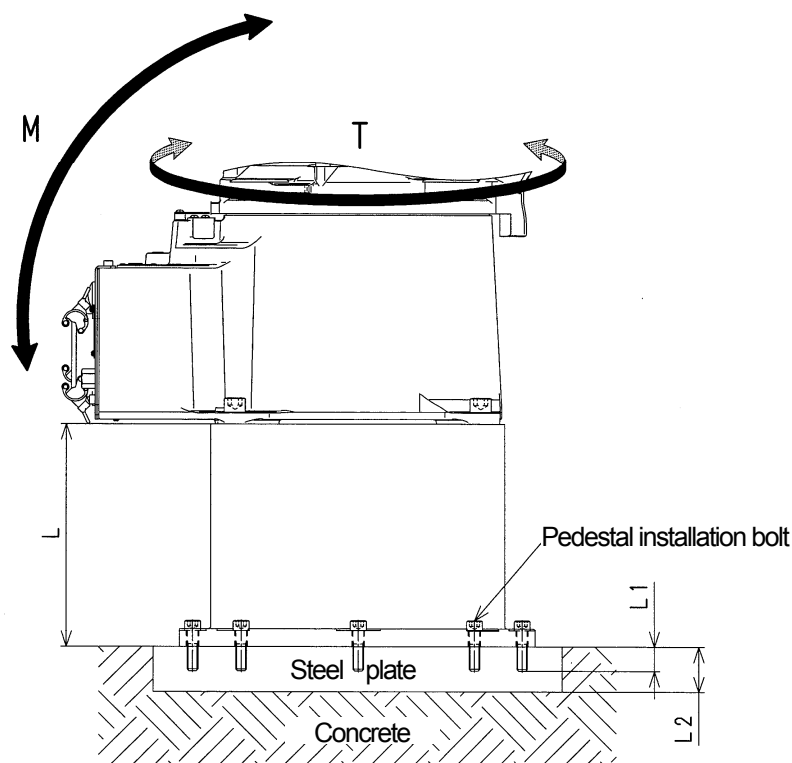

Model	BA006L	BA006N
M (Inversion moment)	2982 N·m	2527 N·m
T (Rotating torque)	2200 N·m	1935 N·m
Pedestal mass	70 kg(L=600)	
	45 kg(L=300)	
Pedestal installation bolt	8-M12	
Tightening torque	98 N·m	
L	600(60360-1166*)	
	300(60360-1167*)	
L1	Min. 18 mm	
L2	Min. 20 mm	

**NOTE\*** ( ) indicates the part number of pedestal.

### 7.3 WHEN INSTALLING THE ROBOT BASE PLATE ON THE FLOOR

In this case, install the base plate on concrete floor or steel plate using bolt holes on the base plate.

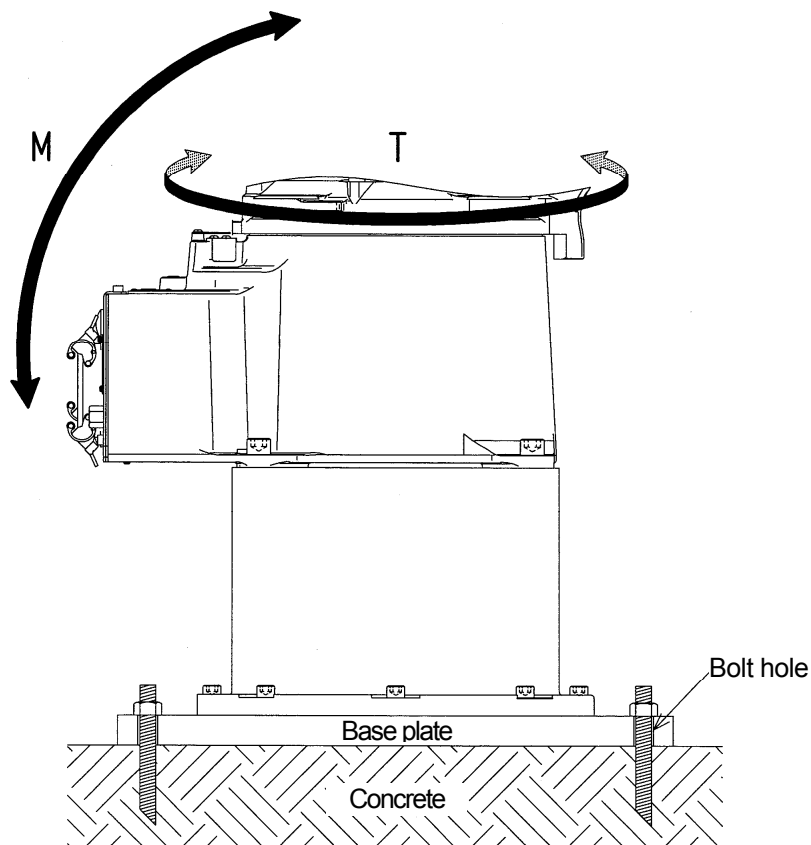

Model	BA006L	BA006N
M (Inversion moment)	2982 N·m	2527 N·m
T (Rotating torque)	2200 N·m	1935 N·m
Base plate mass	110 kg	
Base plate installation hole	4-φ20 (PCD800)	
Base plate dimension (mm)	750 × 750 × 25	

## 8.0 MOUNTING OF TOOLS

**⚠ WARNING**

**Prior to mounting tools on the robot, turn OFF the controller power switch and the external power switch. Display signs indicating clearly “Installation and connection in progress”, and lockout/tagout the external power switch to prevent personnel from accidentally turning ON the power.**

### 8.1 DIMENSIONS OF WRIST END

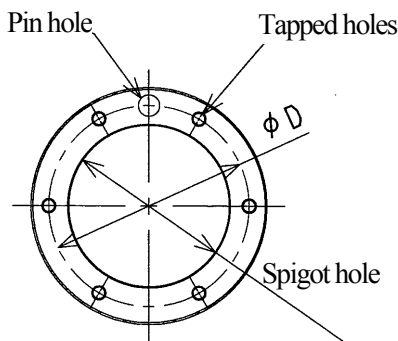

In the robot arm end section, a flange is provided on which a tool is mounted. Screw the mounting bolts into the tapped holes on the circumference of  $\phi D$  on the flange, referring to the figure on the left. Moreover, position the tool by utilizing the pin hole and the spigot hole.

### 8.2 SPECIFICATION OF MOUNTING BOLT

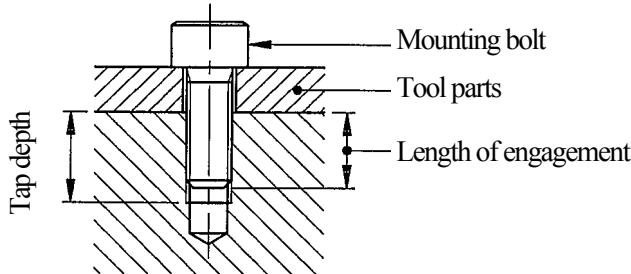

Select mounting bolts with proper length to secure the specified engagement length. Use high tension mounting bolt and tighten them to the specified torque.

**⚠ CAUTION**

**If the engagement length has exceeded the specified value, the mounting bolt might bottom out, and the tool will not be fixed securely.**

Model	All models
Tapped holes	6-M4
$\phi D$	$\phi 56$
Pin hole	$\phi 6H7$ Depth 8
Spigot hole	$\phi 45H7$ Depth 5
Tap depth	8 mm
Length of engagement	6 - 7 mm
High tension bolt	SCM435, 10.9 min
Tightening torque	3.43 N·m

### 8.3 LOAD CAPACITY

Load mass applicable to robot is specified for each model and includes the mass of tool, etc. Applicable load torque and moment of inertia around wrist axes (JT4, JT5, JT6) are also specified. Strictly observe the following restrictions on them.

**⚠ CAUTION**

**Using the robot beyond its specified load may result in degradation of movement performance and shortening of machine service life. The load mass includes the tool mass such as hand, tool changer, shock absorber, etc. If using the robot in excess of its load capacity, first contact Kawasaki without fail.**

The load torque and the moment of inertia can be calculated by the expression below:

Calculation Expression

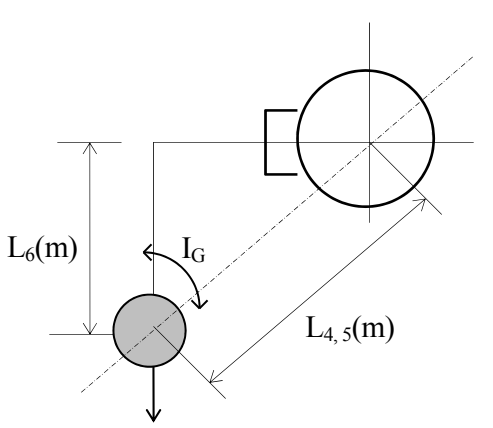

$M(\text{kg})$      $L$ : Length from axis rotation center to load center of gravity. (Unit: m)  
 $L_6$ : Length from JT6 axis rotation center to load center of gravity.  
 $L_{4,5}$ : Length from JT4(5) axis rotation center to load center of gravity.  
 $I_G$ : Moment of inertia around center of gravity. (Unit:  $\text{kg}\cdot\text{m}^2$ )

Load mass :  $M \leq M_{\text{max}}$  (kg)  
(including tool)

Load torque :  $T = 9.8 \cdot M \cdot L$  (N·m)

Load moment of inertia:  $I = M \cdot L^2 + I_G$  ( $\text{kg}\cdot\text{m}^2$ )

$M_{\text{max}}$ : Maximum load mass: See 3.2.

If calculation of load is made by dividing the load into construction parts, such as tools and workpieces, use the total calculation values of each part as load torque and moment of inertia.

Regarding the load on the robot wrist section, meet the following restriction conditions:

1. The load mass including tool mass should be less than the following value.  
BA006 = 6 kg
2. The load torque and the moment of inertia around each wrist axis (JT4, JT5, JT6) should be within the following restriction\*:

**NOTE\*** Load moment of inertia exceeding the restriction may be acceptable. In this case, ensure to specify the load. (However, the robot movement may become slow or shake easily because of adjusting acceleration and deceleration.) See “AS Language Reference Manual” for setting the load. Operating the robot with wrong settings may result in degradation of movement performance and shortening of machine service life.

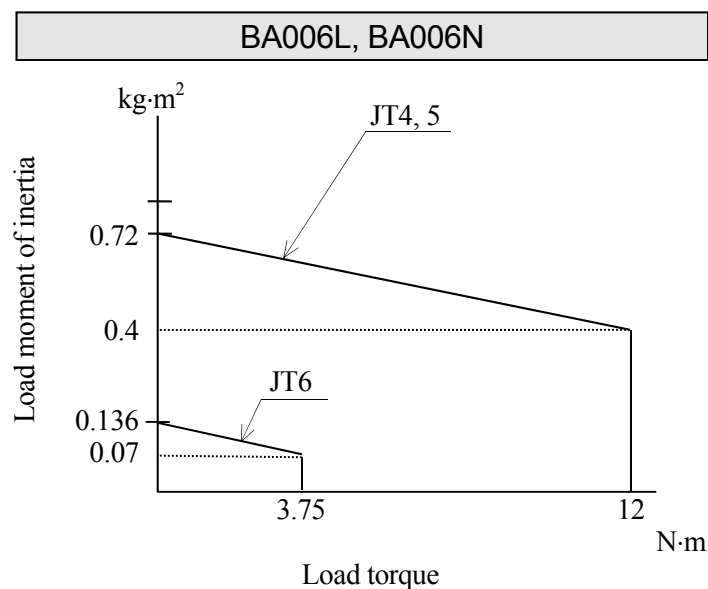

## 9.0 MOUNTING EXTERNAL EQUIPMENT

### 9.1 SERVICE TAPPED HOLE POSITIONS

Service tapped holes shown in the figure below are available to mount wiring brackets and external equipment on each part of robot arm.

**⚠ CAUTION**

**Check the robot movement very carefully and confirm that mounted brackets and external equipment do not interfere with peripheral equipment and robot arm itself.**

BA006L, BA006N

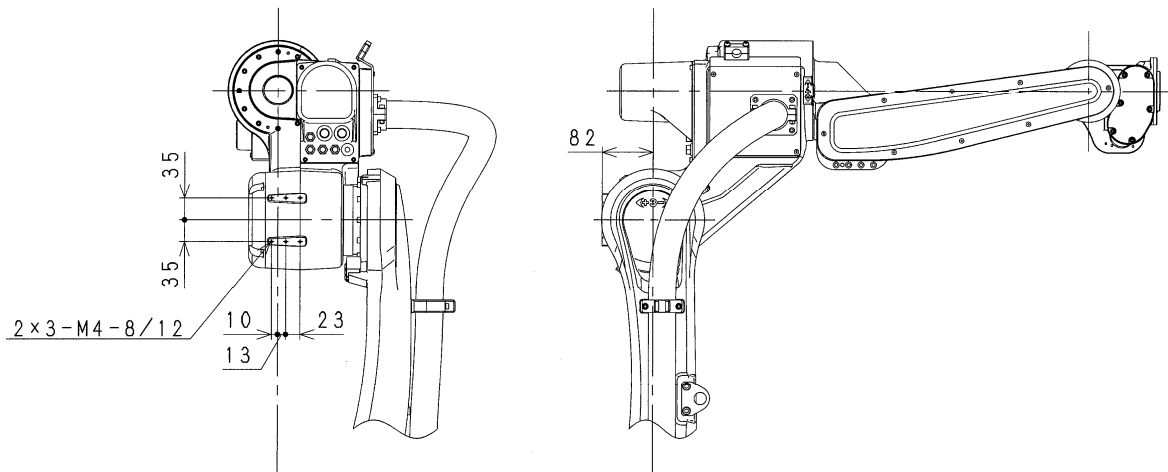



---

**Kawasaki Robot BA Series**  
**Installation and Connection Manual**

---

October 2014 : 1st Edition  
October 2016 : 2nd Edition

Publication : KAWASAKI HEAVY INDUSTRIES, LTD.

90202-1144DEB